

Full Clock Summary

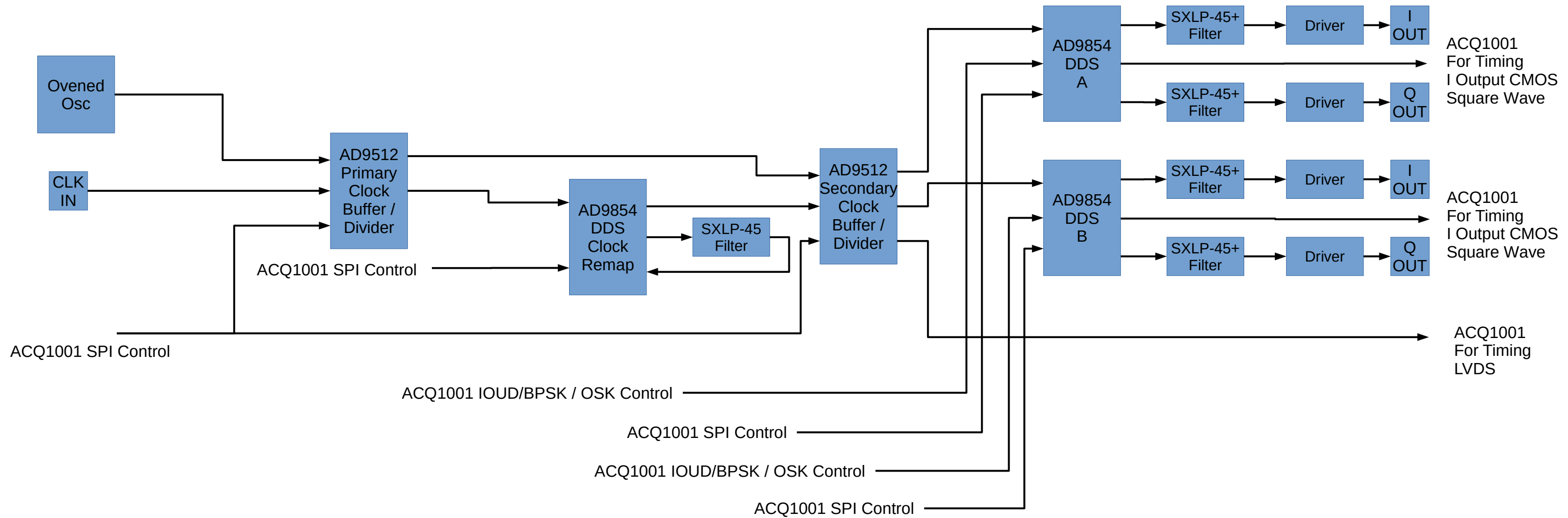

New Clock Scheme

Retained Features

- All DDS devices have independent SPI Buses for potential synchronous updates
- Clock can be either Input MCX or Oven Oscillator
- Clock Remap DDS can be selectively populated

Improvements

- All Clock set up is now programmable – No Jumpers
- Software could detect presence of CLK IN and have a “fall over” to local Oscillator
- or simply have a configuration switch

Restrictions

- Both AD9512 devices must be populated (may be possible to improve on this but tracking will be more complex)
- Both “A” and “B” DDS devices are sourced from the same reference clock, no second “CLK IN” MCX available